

**ARANDELA DIN 9021 CINCADA**  
**ZINC PLATED WASHER DIN 9021**

**FICHA TÉCNICA**  
 TECHNICAL DATA SHEET

**Material / Material:** Acero / Steel  
**Recubrimiento / Coating:** Cincado / Zinc plated

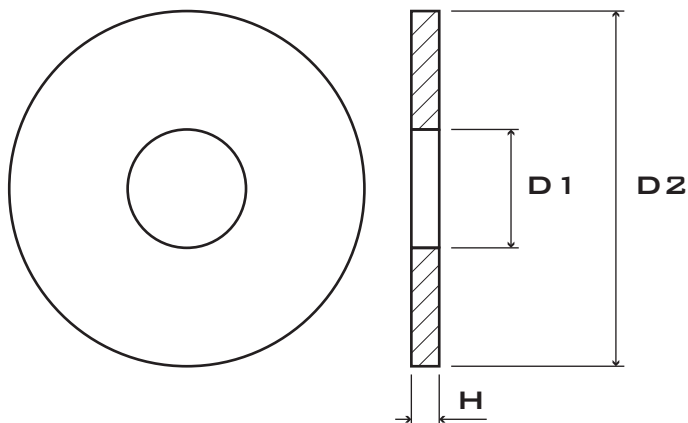

**MEDIDAS / MEASURES**

Medidas en mm / Measures in mm

MÉTRICA TLLD. / SCREW METRIC	D 1	D 2 (MAX)*	H
M2	2,2	7,0	0,8
M2,5	2,7	8,0	0,8
M3	3,2	9,0	0,8
M3,5	3,7	11,0	0,8
M4	4,3	12,0	1,0
M5	5,3	15,0	1,2
M6	6,4	18,0	1,6
M7	7,4	22,0	2,0
M8	8,4	24,0	2,0
M10	10,5	30,0	2,5
M12	13	37,0	3,0
M14	15	44,0	3,0
M16	17	50,0	3,0
M18	19	56,0	4,0
M20	22	60,0	4,0
M22	23	66,0	5,0
M24	26	72,0	5,0
M30	33	92,0	6,0
M36	39	110,0	6,0

\* Diámetro exterior = 3 x diámetro nominal de rosca / Washers with outside diameter = 3 x nominal thread diameter