

TORNILLO FOSFATADO PARA CARTÓN-YESO PHOSPHATED DRYWALL SCREW FOR PLATERBOARD

FICHA TÉCNICA TECHNICAL DATA SHEET

Material / Material:
Recubrimiento / Coating:

Acero cementado / Hardened steel
 Fosfatado negro / Black phosphated



DATOS TÉCNICOS / TECHNICAL DATA

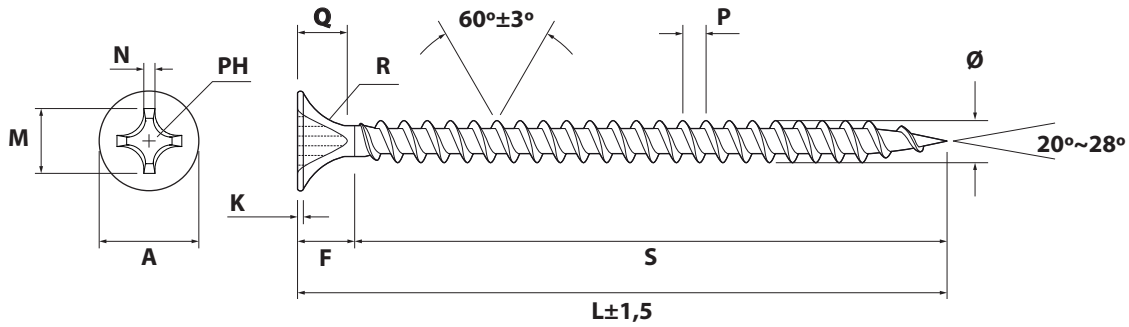

CÓDIGO Code	MEDIDA Measure ØxL m.m.	LLAVE Wrench PH	PAR DE APRIETE Torque Nm	GROSOR A FIJAR Thickness to fix m.m.	A m.m.	Q m.m.	M m.m.	F m.m.	P m.m.	D m.m.
PLADUR35025	3,5x25	2	2	5 - 19	7,9	2,5 - 3,0	4,5 - 5,1	4,5 - 7	1,4 - 1,7	3,3 - 3,6
PLADUR35035	3,5x35	2	2	5 - 29	7,9	2,5 - 3,0	4,5 - 5,1	4,5 - 7	1,4 - 1,7	3,3 - 3,6
PLADUR35045	3,5x45	2	2	5 - 39	7,9	2,5 - 3,0	4,5 - 5,1	4,5 - 7	1,4 - 1,7	3,3 - 3,6

CARGAS DE TRACCIÓN RECOMENDADA (Acero estructural EN 10025)* / RECOMMENDED TENSION LOADS (Structural steel EN 10025)*

Grosor acero / Steel thickness [mm]	0,6	0,8	1,0	1,5
Tornillo Ø3,5mm / Screw Ø3,5mm [kN]	-	0,2	0,3	0,7

* La carga de tracción recomendada deriva de la máxima carga aplicable incluyendo un coeficiente de seguridad $\gamma = 2$

* The recommended tensile load is derived from the maximum applicable load including a safety factor $\gamma = 2$

