

ANILLA ELEVACIÓN MACHO DIN 580 INOXIDABLE A-4 STAINLESS STEEL AISI 316 EYE BOLTS DIN 580

FICHA TÉCNICA TECHNICAL DATA SHEET

Material / Material:
Recubrimiento / Coating:

Acero inoxidable A-4 / Stainless steel AISI 316
 Pulido / Polish

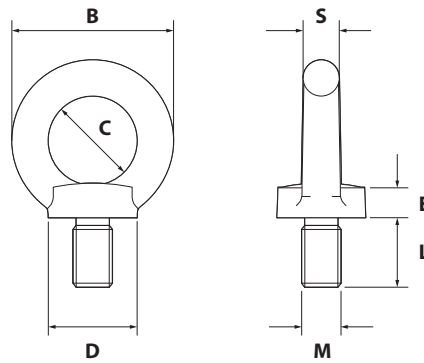

CÓDIGO Code/Code	MEDIDA Measure/Mesure	* CMU 	* CMU / 45°	PA.	B	C	D	E	L	S	PESO Weight/Poids
	M	0°	45°								
	m.m.	Kg	Kg	Nm	m.m.	m.m.	m.m.	m.m.	m.m.	m.m.	Kg.
580A406	M6	90	60	3,5	36	20	20	6	13	8	0,05
580A408	M8	140	100	8	36	20	20	6	13	8	0,06
580A410	M10	230	170	16	45	25	25	8	17	10	0,12
580A412	M12	340	240	28	54	30	30	10	20,5	12	0,18
580A414	M14	500	350	45	54	30	30	10	20,5	12	0,19
580A416	M16	700	500	70	63	35	35	12	27	14	0,31
580A420	M20	1.200	860	135	72	40	40	14	30	16	0,44

CMU.: Carga máxima de utilización / CMU.: Working load limit / CMU.: Charge maximale d'utilisation / CMU.: Höchste tragfähigkeit