

ANILLA MAESTRA OVAL ENSAMBLADA GRADO 80

SUB-ASSEMBLY OBLONG MASTERLINK GRADE 80

FICHA TÉCNICA

TECHNICAL DATA SHEET

Material / Material:
Recubrimiento / Coating:

Acero carbono / Carbon steel
 Lacado rojo / Red lacquered

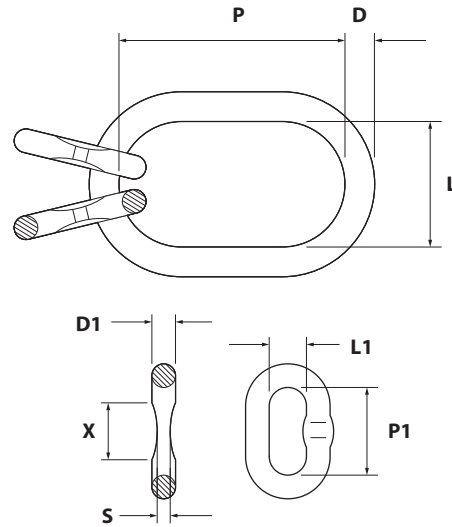

CÓDIGO Code / Code	Ø CADENA Chain Ø / Ø Chaîne	* CMU 0°-45° Tn	* CMU 45°-60° Tn	D	P	L	D1	P1	L1	SxX	PESO Weight / Poids
	↕ ↕			m.m.	m.m.	m.m.	m.m.	m.m.	m.m.	m.m.	Kg/m
AMOE06	6	2,36	1,70	18	135	75	13	54	25	8x25	1,31
AMOE08	8	4,25	3,00	22	160	90	16	70	34	8x25	2,32
AMOE10	10	6,70	4,75	26	180	100	18	85	40	11,5x35	3,52
AMOE13	13	11,20	8,00	32	200	110	22	115	50	14x35	6,26
AMOE16	16	17,00	11,80	36	260	140	26	140	65	18x46	9,56
AMOE18 ¹	18	21,20	15,00	45	340	180	32	150	70	-	18,92
AMOE20 ¹	20	26,50	19,00	51	350	190	32	150	70	-	22,65
AMOE22 ¹	22	31,50	22,40	51	350	190	36	170	75	-	25,19
AMOE26 ¹	26	45,00	31,50	57	400	200	40	170	80	-	36,01

¹ Medidas disponibles bajo pedido / Measurements available on request

* CMU.: Carga máxima de utilización / CMU.: Working load limit