

MOSQUETÓN BOMBERO DIN 5299 CINCADO

ZINC PLATED SNAP HOOK DIN 5299

FICHA TÉCNICA

TECHNICAL DATA SHEET

MATERIAL /
MATERIAL:

ACERO FE 360 B
FE 360 B STEEL

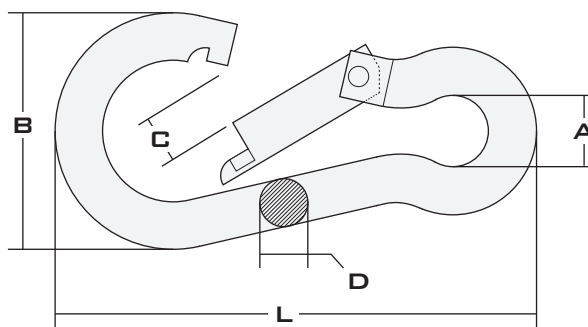

CÓDIGO CODE CODE	MEDIDA SIZE MEASURE	CMA.	A	B	C	PESO WEIGHT POIDS
	(DxL) m.m.	Kg.	m.m.	m.m.	m.m.	Kg.
MBZ040	4x40	30	7	14	6	0,01
MBZ050	5x50	100	8	15	7	0,02
MBZ060	6x60	120	9	17	8	0,02
MBZ070	7x70	180	10	19	8	0,04
MBZ080	8x80	230	12	23	10	0,07
MBZ090	9x90	250	12	24	10	0,09
MBZ100	10x100	350	15	29	11	0,13
MBZ120	11x120	380	18	36	16	0,19
MBZ140	12x140	400	20	40	19	0,20