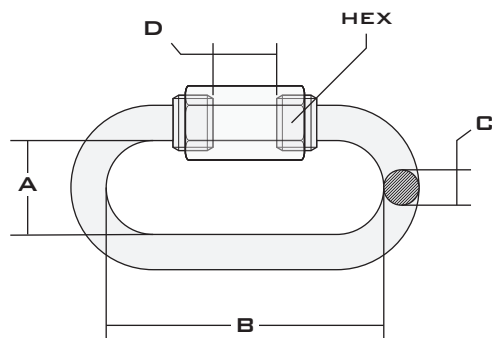

MALLA RÁPIDA CINCADA
ZINC PLATED QUICK LINK
FICHA TÉCNICA

TECHNICAL DATA SHEET

MATERIAL /
MATERIAL:
ACERO FE 360 B
STEEL FE 360 B
RECUBRIMIENTO /
COATING:
CINCADO
ZINC PLATED

CÓDIGO CODE CODE	MEDIDA SIZE MESURE	A m.m.	B m.m.	D m.m.	HEXÁGONO HEXAGON HEXAGONE m.m.	PESO WEIGHT POIDS Kg.
	(C) m.m.					
MRZ04	4	12	33	5	8	0,01
MRZ05	5	13	40	6,5	9	0,02
MRZ06	6	15	46	9	11	0,03
MRZ08	8	17,5	58	9,5	14	0,08
MRZ09	9	19	62	10	15	0,11
MRZ10	10	20,5	69	13	17	0,15
MRZ12	12	23,5	80,5	14,5	19	0,23
MRZ14	14	27	97	16	22	0,35
MRZ16	16	29,5	113	21	24	0,45