

## ARANDELA DE NYLON CON TAPÓN Y JUNTA DE ESTANQUEIDAD EN POLIETILENO EXPANDIDO LARGE NYLON WASHER WITH SMALL CAP AND PE FOAM SEALING GASKET

### FICHA TÉCNICA TECHNICAL DATA SHEET

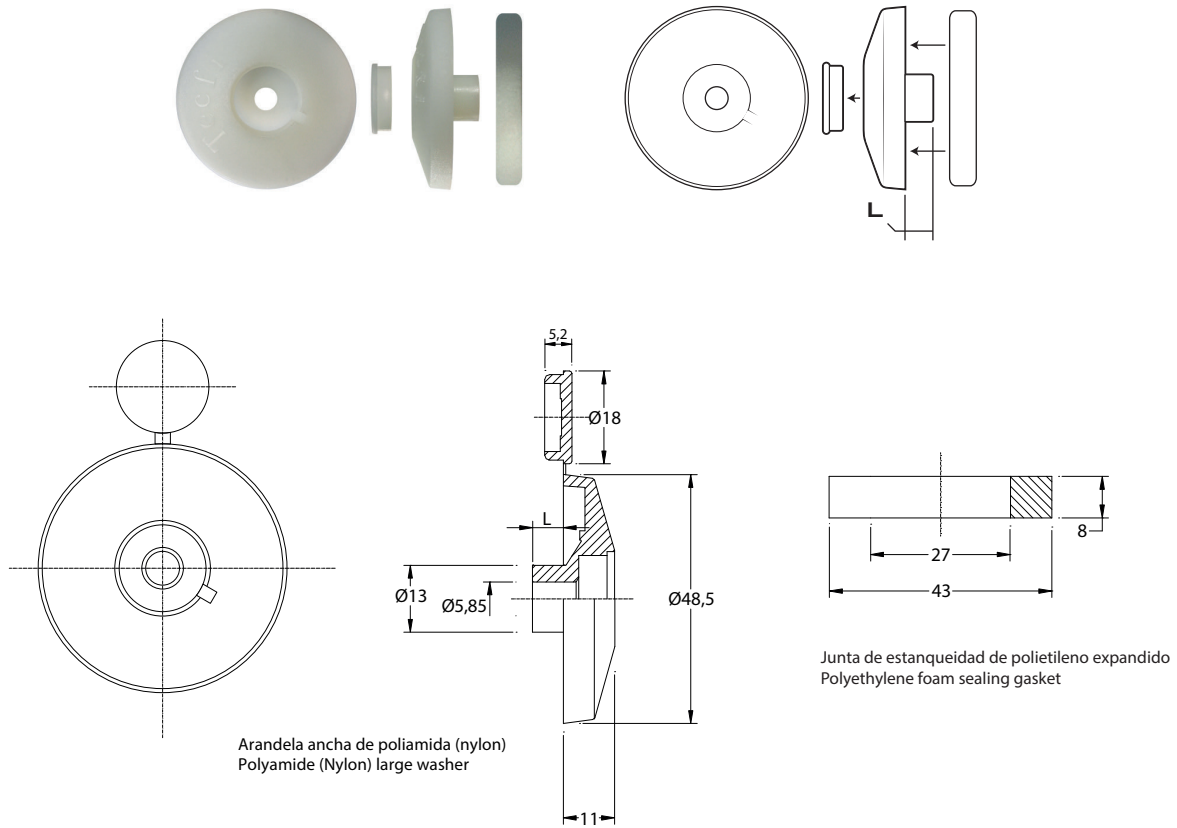

CÓDIGO CODE CODE	GROSOR DE LA LÁMINA SHEET THICKNESS ÉPAISSEUR DE LA TÔLE		EMBALAJE QUANTITY EMBALLAGE
	(L) m.m.		
POLICAR06	6		200
POLICAR10	10		200
POLICAR16	16		200