

**ABRAZADERA REFORZADA M8+M10 - W5**  
**REINFORCED PIPE CLAMP M8 + M10 - W5**

**FICHA TÉCNICA**  
**TECHNICAL DATA SHEET**

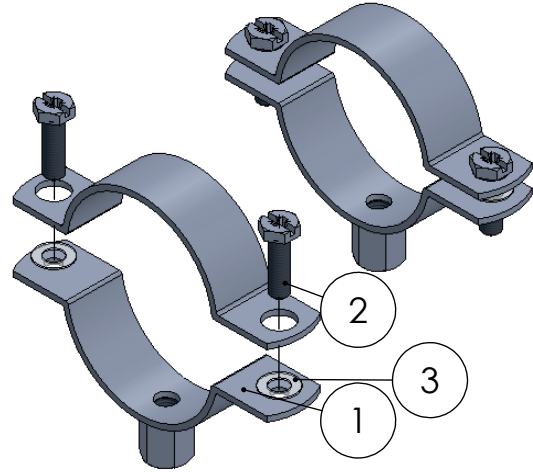
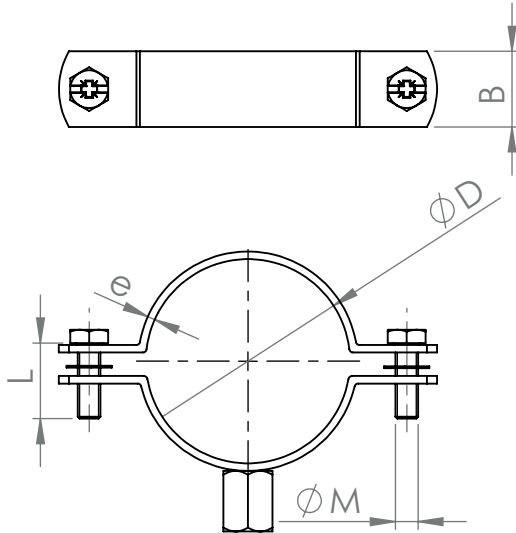

3	Anilla	Washer	-	-
2	Tornillo	Screw	A4-70	-
1	Banda	Band	AISI 316	Pulido
Nº	Pieza	Part	Material	Acabado

Medida/Size		Tornillo	Banda
"	Ø D(mm)	MxL (mm)	Bxe (mm)
3/8	18	M6x16	20x2
1/2	22		
3/4	28		
1"	35		
1 1/4	40		
1 1/2	48	M6x20	
	54		
2"	60		
	70		
2 1/2	75		
	84	M6x25	
3"	90		
	100		
4"	110		
4"	115		
5"	125		
	133		
5"	140		
	150		
	154		
6"	160	M6x30	28x2
	180		
	204		
	220		
	225		
	250		
	280		
	300		
	315		
	350		
	400		
	500		

**Detalle M8+M10**  
**Escala 1:1**

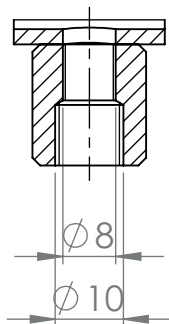

Dibujo Técnico (Título): <b>Abrazadera Reforzada M8+M10 en W5</b>	
Tolerancias Dimensionales Generales DIN ISO 2768- m Tolerancias Geométricas Generales DIN ISO 2768- K Tolerancias ISO 8015	<b>A4</b>
Escala: 1:2	Hoja 1 de 1