

ANILLA MAESTRA OVAL GRADO 80

OBLONG MASTERLINK GRADE 80

FICHA TÉCNICA

TECHNICAL DATA SHEET

Material / Material:
Recubrimiento / Coating:

Acero carbono / Carbon steel
 Lacado rojo / Red lacquered

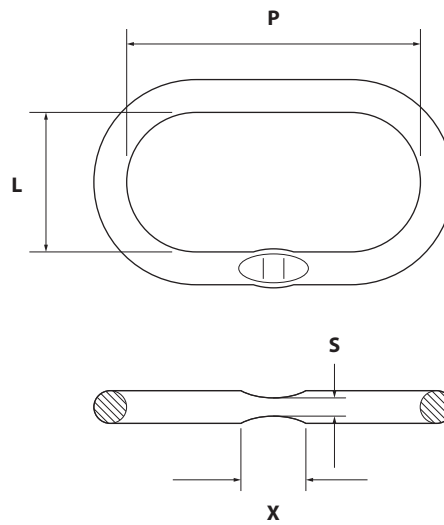

CÓDIGO Code / Code	Ø CADENA Chain Ø / Ø Chaîne		* CMU Tn	D m.m.	P m.m.	L m.m.	SxX m.m.	PESO Weight / Poids Kg.
	⊥	∧						
AMO0706	7	6	1,60	13	110	60	8x25	0,34
AMO0807	8	7	2,12	16	110	60	8x25	0,53
AMO1008	10	8	3,15	18	135	75	8x35	0,92
AMO1310	13	10	5,30	22	160	90	11,5x35	1,60
AMO1613	16	13	8,00	26	180	100	14x46	2,46
AMO1816 ¹	18	16	11,20	32	200	110	18x46	4,14
AMO2018 ¹	20	18	14,00	36	260	140	-	6,22
AMO2220 ¹	22	20	17,00	40	300	160	-	8,95
AMO2622 ¹	26	22	21,20	45	340	180	-	12,82
AMO3226 ¹	32	26	31,50	51	350	190	-	16,55
AMO3632 ¹	36	32	45,00	57	400	200	-	27,01

¹ Medidas disponibles bajo pedido / Measurements available on request

* CMU.: Carga máxima de utilización / CMU.: Working load limit