

GANCHO AUTOCIERRE HORQUILLA GRADO 80

SELF LOCKING CLEVIS HOOK GRADE 80

FICHA TÉCNICA

TECHNICAL DATA SHEET

Material / Material:
Recubrimiento / Coating:

Acero carbono / Carbon steel
 Lacado rojo / Red lacquered

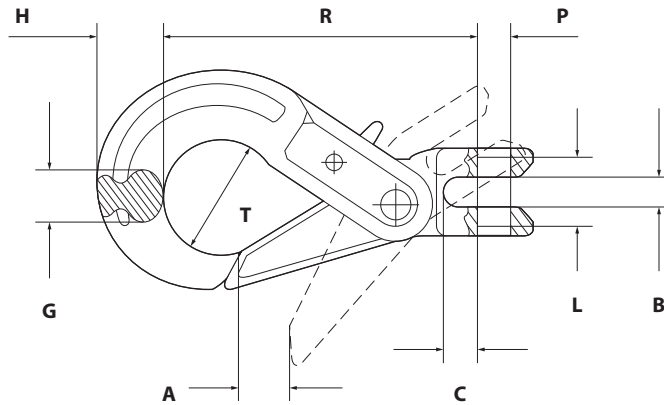

CÓDIGO Code/Code	Ø CADENA Chain Ø / Ø Chaîne	Ø CADENA Chain Ø / Ø Chaîne	* CMU Tn	A	B	C	G	H	R	T	PxL	PESO Weight / Poids
	m.m.	Inch.	Tn	m.m.	m.m.	m.m.	m.m.	m.m.	m.m.	m.m.	m.m.	Kg.
GAH06	6	1/4	1,12	28	7	8	16	21	94	35	7,5x17	0,49
GAH08	7-8	9/32-5/16	2,00	34	9	10	20	26	123	43	9x22,5	0,93
GAH10	10	3/8	3,15	45	12	14	25	30	143	56	13x31,5	1,58
GAH13	13	1/2	5,30	51	15	17	35	40	180	69	16x42	3,20
GAH16	16	5/8	8,00	60	19	19	36	50	215	80	21x51,5	5,95
GAH20	20	3/4	12,50	70	23	26	60	67	253	90	24x73	9,80

* CMU.:Carga máxima de utilización / CMU.: Working load limit